

RR 2068

Firestone



WARNING:

Do not inflate this assembly when it is unrestricted. The assembly must be restricted by the suspension or other adequate structure. Do not inflate beyond 100 P.S.I. Improper use or over inflation may cause property damage or severe personal injury.

Firestone Industrial Products
Carmel, Indiana, USA

INSTALLATION INSTRUCTIONS

Congratulations - your new Ride-Rite Air Helper Springs are quality products capable of improving the handling and comfort of your vehicle. As with all products, proper installation is the key to obtaining all of the benefits your kit is capable of delivering. Please take a few minutes to read through the instructions to identify the components and learn where and how they are used. It is a good idea to start by comparing the parts in your kit with the parts list below.

The heart of the Ride-Rite kit is, of course, the air helper springs. Remember that the air helper springs must flex and expand during operation, so be sure that there is enough clearance to do so without rubbing against any other part of the vehicle.

Be sure to take all applicable safety precautions during the installation of the kit. The instructions listed in this brochure and the illustrations all show the left, or driver's side of the vehicle. To install the right side assembly simply follow the same procedures.

Your kit includes separate inflation valves and air lines for each air helper spring. This will allow you to level your vehicle from side to side as well as from front to back. If you would rather have a single valve inflation system, your dealer can supply the required "T" fitting.

IMPORTANT!

For your safety and to prevent possible damage to your vehicle, do not exceed the maximum load recommended by the vehicle manufacturer (GVWR). Although your Ride-Rite Air Helper Springs are rated at a maximum inflation pressure of 100 P.S.I., this pressure may allow you to carry too great a load on some vehicles. Check your vehicle owner's manual for maximum loads listed for your vehicle.

When inflating your Ride-Rite Air Helper Springs, add air pressure in small quantities, checking pressure frequently during inflation. The air spring requires much less air volume than a tire and, therefore, inflates much quicker.

PARTS LIST

224C AIR SPRING	0335	2		
UPPER BRACKET	5090	2	3/8"-16 X 1 1/2 HEX BOLT	8
LOWER BRACKET	5220	2	5/16" FLAT WASHER	4
BRACKET STRAP	5103	2	PUSH TO CONNECT	
AIR LINE TUBING		1	INFLATION VALVE	3032
3/8"-24 FLANGE NUT		4	PUSH TO CONNECT	
3/8"-16 FLANGE LOCK NUT		12	ELBOW FITTING	3031
3/8"-16 X 3/4" HEX BOLT		4	THERMAL SLEEVE	0899
3/8"-16 x 5-1/2" CARRIAGE BOLTS		4	NYLON TIE	6
3/8" SPECIAL WASHER		8		

RR 2068



NOTE: Both illustrations are of the left, or drivers side, of the vehicle. Reverse any orientations when assembling and installing the right, or passenger, side of the vehicle.

KIT ASSEMBLY

KIT TO FRAME ASSEMBLY

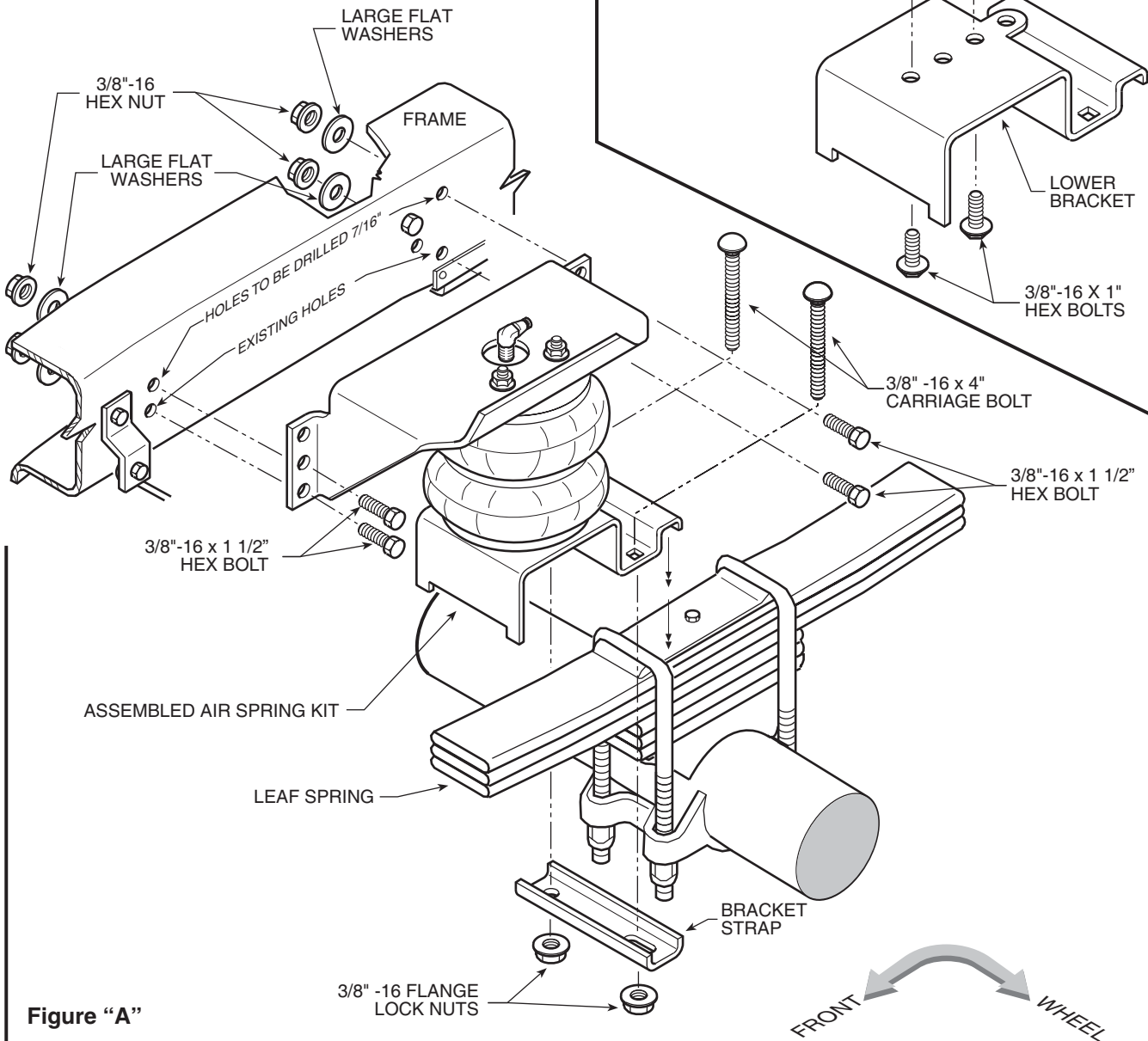
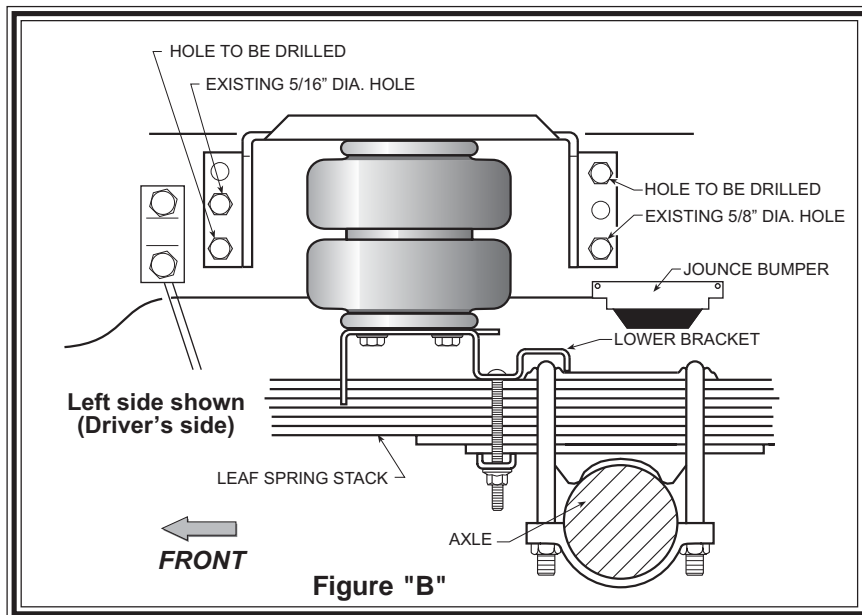

Figure "A"



STEP 1 - PREPARE THE VEHICLE

Make sure that the vehicle is on a solid level surface. Take necessary safety precautions such as using wheel chocks when working under your vehicle. This vehicle does not have to be jacked up to install the kit. Remove the positive battery cable.

STEP 2 - PREASSEMBLE THE RIDE-RITE KIT

Select one air helper spring from your kit and an upper bracket. Align the studs on the air spring with the holes on the upper bracket making sure the air inlet hole can be seen through the slot in the upper bracket see *Figure "A"*. Use the 3/8"-16 flange lock nuts to secure the upper bracket to the air spring. Install the air fitting as shown in *Figure "A"*. Tighten the

air fitting securely to engage the orange thread sealant. Point the elbow fitting in the direction of the inflation valve location. Refer to Step 6 for inflation valve installation. Position the lower bracket as shown in *Figure "A"* & *"B"*. Fasten the lower bracket to the air helper spring using two 3/8"-16 x 3/4" hex bolts.

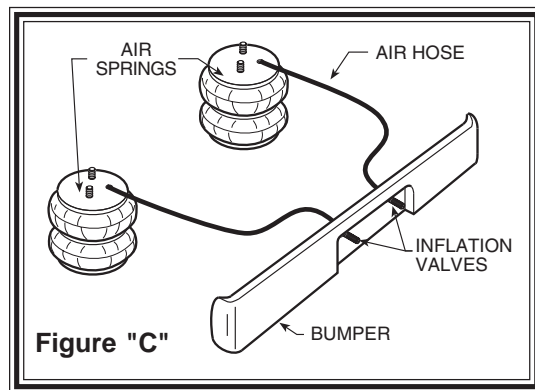

STEP 3 - PRE-FIT MARK AND DRILL HOLES

Position the assembly on the frame as shown in *Figure "A"* & *"B"*. The upper bracket has three holes in each flange. Only two holes in each flange will be used for mounting to the frame. Two mounting holes are matched with existing holes in the frame see *Figure "A"* & *"B"*. One hole is 5/16" in diameter and will need to be drilled out using a 7/16" diameter drill bit. **Before drilling the holes make sure all electrical, brake and fuel lines are cleared from the path of the drill.** Damage to lines can be avoided by inserting a piece of wood between the frame rail and any lines in the path of the drill. The other hole is 5/8" diameter and will require the use of a 3/8" special washer behind the frame rail. The 3/8" diameter washers should also be placed on the inside of the frame rail behind each upper bracket fastener. Bolt the upper bracket to the existing holes in the frame as shown in *Figure "A"*. Using the bracket as a template drill a 7/16" hole in each of the upper flange holes shown in *Figure "A"* & *"B"*. Complete the attachment of the upper bracket to the frame using the 3/8"-16 x 1-1/2" hex bolts, washers and nuts.

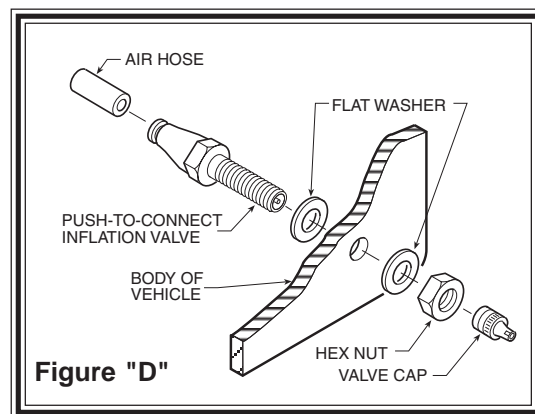

STEP 4 - LOWER BRACKET ATTACHMENT

Mount the lower bracket to the leaf spring stack by sliding the lower bracket to the leaf spring retainer see *Figure "B"*. Make sure the lower bracket is placed so that the retainer and leaf spring "U"-bolt is captured by the lower bracket as shown in *Figure "B"*. Install 3/8"-16 x 5-1/2" carriage bolts in the square holes of the lower bracket. The lower bracket is then secured by a bracket strap which is placed under the leaf spring stack and retained with 3/8"-16 flanged lock nuts.

STEP 5 - INSTALLATION TO THE PASSENGER'S SIDE ASSEMBLY

Follow steps 1-4 for assembly and installation of the passenger's side assembly. Reverse any orientations when assembling and installing the right, or passenger, side of the vehicle. Please note that when installing the kit on the passenger's side of the vehicle, the upper bracket will locate again on the existing holes in the frame. However,

NOTE:

Once the air helper springs are installed, it is recommended that the vehicle not be lifted by the frame, as over-extension may occur, resulting in damage to the air helper springs. However, should it become necessary to raise the vehicle by the frame, deflate both air helper springs completely.

one existing frame hole must be drilled out to bolt the upper bracket to the frame due to a heat shield covering the hole from the inside of the vehicle frame. This heat shield material must be removed using a 7/16" drill bit to allow the fastener to pass through the hole.

STEP 6 - INSTALL THE AIR LINE AND THE INFLATION VALVE

Uncoil the air line tubing and cut it into two equal lengths. **DO NOT FOLD OR KINK THE TUBING.** Try to make the cut as square as possible. Insert one end of the tubing into the elbow fitting installed in the top of the air helper spring. Push the tubing into the fitting as far as possible refer to *Figure "A"*.

Select a location on the vehicle for the air inflation valves. The location can be on the bumper or the body of the vehicle, as long as it is in a protected location so the valve will not be damaged, but maintain accessibility for the air chuck see *Figure "C"*. Drill a 5/16" hole and install the air inflation valve using two 5/16" flat washers per valve as supports see *Figure "D"*. Run the tubing from the air helper spring to the inflation valve, routing it to avoid direct heat from the engine, exhaust pipe, and away from sharp edges. Thermal sleeves have been provided for these conditions. If a thermal sleeve is required simply slide the sleeve over the air line tubing to the location requiring protection. The air line tubing should not be bent or curved sharply as it may buckle. Secure the tubing in place with the nylon ties provided. Push the end of the air line tubing into the inflation valve as illustrated see *Figure "D"*.

STEP 7 - CHECK THE AIR SYSTEM

Once the inflation valves are installed inflate the air helper springs to **70 P.S.I.** and check the fittings for air leaks with an applied solution of soap and water. If a leak is detected at a tubing connection then check to make sure that the tube is cut as square as possible and that it is pushed completely into the fitting. The tubing can easily be removed from the fittings by pushing the collar towards the body of the fitting and then pulling out the tube. If a leak is detected where the brass elbow fitting screws into the spring, remove the tubing (see trouble shooting section of the operating instruction manual for removal procedure), then screw the elbow into the air spring one additional turn or until the leak stops. Reinstall the tubing and reinflate the air springs and check for leaks as noted above. Further information on trouble-shooting can be found in the General Operation Instruction book included with this kit.

This now completes the installation. Re-attach the positive battery cable and remove the wheel chocks from the rear wheels. Before proceeding, check once again to be sure you have proper clearance around the air springs. With a load on your vehicle and the air helper springs inflated, you must have at least 1/2" clearance around the air springs. As a general rule, the Ride-Rite Air Helper Springs will support approximately 50 lbs. of load for each P.S.I. of inflation pressure (per pair). For example, 50 P.S.I. of inflation pressure will support a load of 2500 lbs. per pair of air helper springs. **FOR BEST RIDE** use only enough air pressure in the air helper springs to level the vehicle when viewed from the side (front to rear). This amount will vary depending on the load, location of load, condition of existing suspension and personal preference.

NOTE:

Too much air pressure in the air helper springs will result in a firmer ride, while too little air pressure will allow the air helper spring to bottom out over rough conditions. Too little air pressure will also not provide the improvement in handling that is possible. **TO PREVENT POSSIBLE DAMAGE MAINTAIN A MINIMUM OF 20 P.S.I. IN THE RIDE-RITE AIR HELPER SPRINGS AT ALL TIMES.**

Enclosed with this kit are Ride-Rite Operating Instructions. Please read them for proper and safe operation.

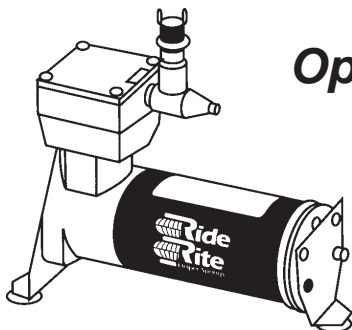

Optional Air Convenience Systems Available

Providing instant air supply and air pressure adjustment.

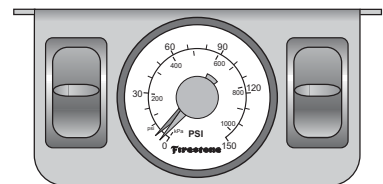

The air convenience system can be easily added to your existing Ride-Rite kit by re-routing the air line tubing.

For more information on air convenience systems, contact your dealer or Firestone at 1-800-247-4337

Firestone

FIRESTONE INDUSTRIAL PRODUCTS CARMEL, INDIANA 46032
TELEPHONE: 317-818-8600 TELEPHONE: 1-800-247-4337 FAX 317-818-8645
www.firestoneindustrial.com